

## DESCRIPTION

Unipower's **SGG3000** is a new generation of high density hot-swap Front-Ends for Networking and DataCom applications that utilize 12V Bus Architecture. With a power density of 14.5W/in<sup>3</sup> and efficiency of 92%, these "GREEN" power solutions help system designers satisfy increasing demands for reduced energy consumption, smaller size and reduced costs.

These 500 Watt Power Modules feature both Analog and PMBus communication for status and control of each power module. Front panel LED indicator and Audible alarm communicates status or fault conditions for easy identification in any environment. N+N Redundant operation is achieved with active load sharing and ORing protection circuits.

## FEATURES

- ◆ Up to 92% Efficiency
- ◆ 1U High: 1.57"
- ◆ 0°C to +45°C Operation
- ◆ Universal AC Input
- ◆ >0.95 Power Factor (minimum)
- ◆ Output Voltages: 12 VDC & 5VSB
- ◆ Power Density to 14.5W/in<sup>3</sup>
- ◆ Hot Swappable
- ◆ Integral Active Output ORing Circuit
- ◆ Class B EMI Filter
- ◆ LED Indicators
- ◆ PMBus Serial Communications
- ◆ Variable Speed Cooling Fans

## TWO-YEAR WARRANTY

## INTERNATIONAL STANDARDS

UL/cUL 60950-1, TUV EN 60950-1  
CB IEC 60950-1, WEEE, CE Mark (LVD)



## 12V FRONT END MODULE

POWER	12VOUT	5VSB	MODEL NO.
500W	41A	3A	SGG3000

\* Total power May Not Exceed 500 Watts

## 1. Purpose

This specification defines the performance characteristics and functions of a 500 watts 1U form factor of power supply module with Active PFC (Power Factor Correction) and PMBus (Power Management Bus).

## 2. AC Input Requirements

### 2.1 Input Voltage and Frequency

Voltage (sinusoidal) : 100~240 VAC full range, with  $\pm 10\%$  tolerance. Input frequency ranges from 47hz~63hz

### 2.2 AC Input Current and Inrush Current

AC line inrush current shall not damage any component nor cause the AC line fuse to blow under any DC conditions and with any specified AC line input voltage and frequency. Inrush current is tested at 25 °C ambient and cold start within 1/4 AC cycle. Repetitive On/Off cycling of the AC input voltage shall not damage the power supply.

**Table 1: AC Input Current and Inrush Current**

Input Voltage	Input Current	Inrush Current
100~240VAC	7~3.5A	35A peak@115VAC 70A peak@240VAC

### 2.3 Input Power Factor Correction (Active PFC)

The power factor at 100% of rated load shall be  $\geq 0.95$  at nominal input voltage and full load.

### 2.4 AC Line Transient Specification

AC line transient conditions are characterized as “sag” and “surge” conditions. Sag conditions (also referred to as “brownout” conditions) will be defined as the AC line voltage dropping below nominal voltage. Surge conditions will be defined as the AC line voltage rising above nominal voltage. The power supply shall meet the regulation requirements under the following AC line sag and surge conditions.

**Table 2: AC Line Sag Transient Performance**

Duration	Sag	Operating AC Voltage	Line Frequency	Load	Performance Criteria
Continuous	10%	Nominal AC Input ranges	50/60 Hz	100%	No loss of function or performance
0-1 AC cycle	100%	Nominal AC Input ranges	50/60 Hz	70%	No loss of function or performance
> 1 AC cycle	> 10%	Nominal AC Input ranges	50/60 Hz	100%	Loss of function Acceptable

**Table 3: AC Line Surge Transient Performance**

Duration	Surge	Operating AC Voltage	Line Frequency	Performance Criteria
Continuous	10%	Nominal AC Voltage	50/60 Hz	No loss of function or performance
0 - 1/2 AC cycle	30%	Mid-point of Nominal AC Voltage	50/60 Hz	No loss of function or performance

### 3. DC Output Specification

#### 3.1 Output Power / Currents

**Table 4: Load Range**

Voltage	Minimum Load	Maximum Continuous Load
+12V	1A	41A
+5VSB	0A	3A

#### 3.2 Voltage Regulation, Ripple and Noise

**Table 5: Regulation, ripple and noise**

Output Voltage	+12V	+5VSB
Load Reg.	±5%	±5%
Line Reg.	±1%	±1%
Ripple & Noise	120mV	60mV

Ripple and noise shall be measured using the following methods:

- Measurements made differentially to eliminate common-mode noise
- Ground lead length of oscilloscope probe shall be  $\leq 0.25$  inch.
- Measurements made where the cable connectors attach to the load.
- Outputs bypassed at the point of measurement with a parallel combination of 10uF tantalum capacitor in parallel with 0.1uF ceramic capacitors.
- Oscilloscope bandwidth of 0 Hz to 20MHz.
- Measurements measured at locations where remote sense wires are connected.
- Regulation tolerance shall include temperature change, warm up drift and dynamic load

#### 3.3 Capacitive Loading

The power supply shall be stable and meet all requirements in the following table, except dynamic loading requirements.

**Table 6: Capacitive Loading Conditions**

Output	MIN	MAX	Units
+12V	10	11,000	uF
+5VSB	1	350	uF

#### 3.4 Dynamic Loading

The output voltages shall remain within the limits specified in **Table-Regulation, ripple and noise** for the step loading and within the limits specified in **Table-Transient Load Requirement** for the capacitive loading. The load transient repetition rate shall be tested between **50Hz and 5kHz** at duty cycle ranging from 10%-90%. The load transient repetition rate is only a test specification. The  $\Delta$  step load may occur anywhere within the MIN load to the MAX load shown in **Table-Load Range**.

**Table 7: Transient Load Requirements**

Output	$\Delta$ Step Load Size	Load Slew Rate	Capacitive Load
+12V	50% of Max. Load	0.5 A/uS	2200 uF
+5VSB	50% of Max. Load	0.5 A/uS	1 uF

### 3.5 Overshoot at Turn-on/Turn-off

Any output overshoot at turn on shall be less than 10% of the nominal output value. Any overshoot shall recover to be within regulation requirements in less than 10ms.

### 3.6 Timing Requirements

**Table 8: Output Voltage Timing**

Item	Description	MIN	MAX	Units
Tvout_rise	Output voltage rise time from each main output	1	20	mS
	Output voltage rise time for the 5Vsb out put	1	25	mS
Tvout_on	All main output must be within regulation of each other within this time.		50	mS
Tvout_off	All main output must leave regulation within this time		400	mS

**Table 9: Turn On/Off Timing**

Item	Description	MIN	MAX	Units
Tsb_on-delay	Delay from AC being applied to +5VSB being within regulation.		1500	mS
Tac_on-delay	Delay from AC being applied to all output voltages being within regulation.		2500	mS
Tvout_holdup	Time all output voltage stay within regulation after loss of AC tested at 70% of maximum load.	17		mS
Tpwok_holdup	Delay from loss of AC deassertion of PWOK tested at 70% of maximum load.	16		mS
Tpson_on_delay	Delay from PSON# active to output voltage within regulation limits.	5	400	mS
Tpson_pwok	Delay from PSON# deactive to PWOK being deasserted.		50	mS
Tpwok_on	Delay from output voltage within regulation limits to PWOK asserted at turn on.	100	500	mS
Tpwok_off	Delay from PWOK deasserted to output voltage dropping out of regulation limits, tested at 70% of maximum load.	1		mS
Tpwok_low	Duration of PWOK being in the deasserted state during an off/on cycle using AC or the PSON# signal. .	100		mS
Tsb_vout	Delay from +5VSB being in regulation to O/Ps being in regulation at AC turn on.	50	1000	mS

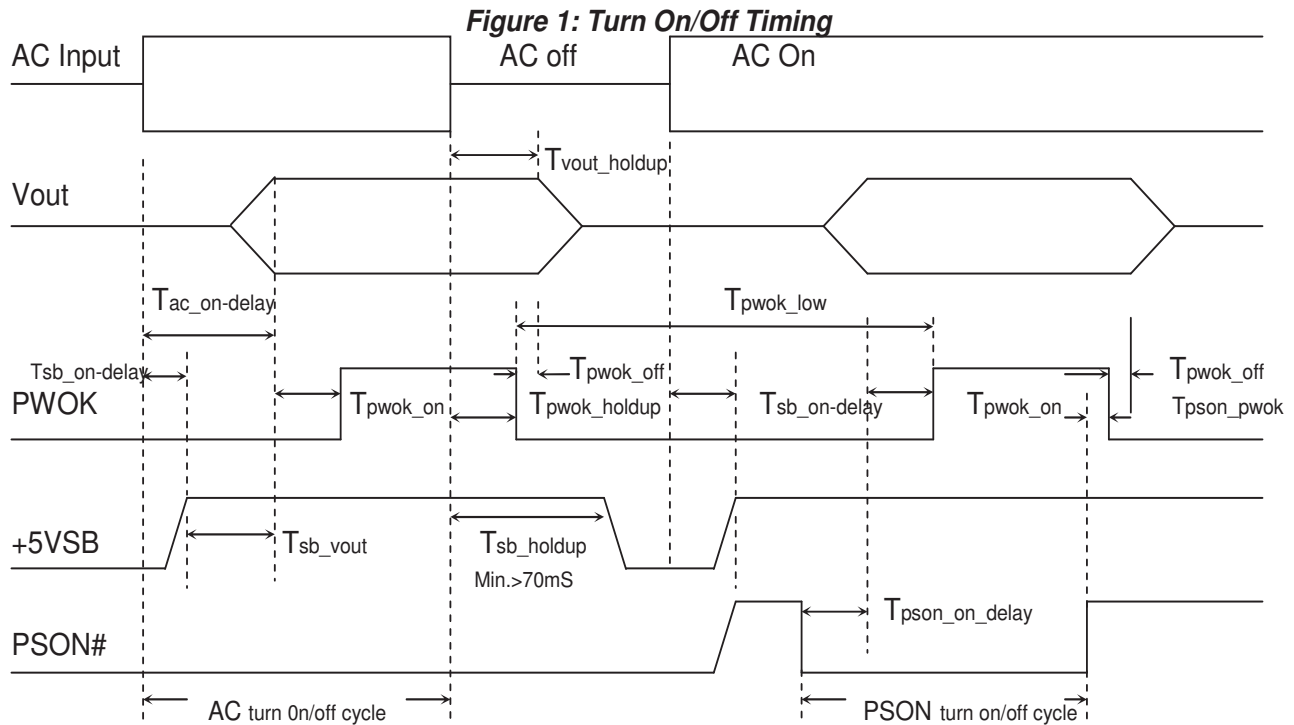

### 3.7 Efficiency

- The power efficiency shall meet 80PLUS gold level standard, tested at 230VAC Input. FAN power is not included into total power consumption.
- Power efficiency shall be at least 82% if tested at 115VAC at 20%~100% of load, and FAN power consumption is included

## 4. Protection Circuits

Protection circuits inside the power supply shall cause only the power supply's main outputs to shutdown. If the power supply latches off due to a protection circuit tripping, an AC cycle OFF for 15 sec and a PSON<sup>#</sup> cycle HIGH for 1 sec must be able to restart the power supply.

### 4.1 Over Current Protection (OCP)

The power supply shall have current limit to prevent +12V outputs from exceeding the values shown in **Table-Over Current Protection**. The power supply shall latch off if the current exceeds the limit.

**Table 10: Over Current Protection**

Voltage	Minimum	Maximum	Shutdown Mode
+12V	44A	63A	Latch Off

### 4.2 Over Voltage Protection (OVP)

The power supply is protected against over voltage due to an internal regulator failure. When an over voltage condition is detected, all DC outputs are disabled (except the +5 VSB). The fault must be removed to restore the DC outputs. The limits are given in Table 11.

**Table 11: Over Voltage Protection**

Voltage	Minimum	Maximum	Shutdown Mode
+12V	+13.3V	+14.5V	Latch Off

### 4.3 Short Circuit Protection

The power supply shall shut down in latch off mode when the output voltage is short circuit.

### 4.4 No Load Operation

No damage or hazardous condition should occur with all the DC output connectors disconnected from the load. The power supply may latch into the shutdown state.

### 4.5 Over Temperature Protection (OTP)

The power supply will shut down when an over temperature condition occurs; no damage shall be caused.

## 5. Environmental Requirements

### 5.1 Temperature

Operating Ambient, normal mode (inlet air): 0°C ~ 45°C (32°F~ 113°F)

Non-operating Ambient:: -40°C ~ 70°C (-40°F~ 158°F)

### 5.2 Humidity

Operating: 20% ~ 90%RH non-condensing

Non-Operating: 5% ~ 95%RH non-condensing

### 5.3 Altitude

Operating: Sea level to 10,000 ft

Non Operating: Sea level to 40,000 ft

### 5.4 Mechanical Shock

Non-Operating: 50 G Trapezoidal Wave, 11mS half sin wave. The shock is to be applied in each of the orthogonal axes.

### 5.5 Vibration (Non-Operating)

The power supply shall be subjected to a vibration test consisting of a 10 to 300 Hz sweep at a constant acceleration of 2.0g for duration of one (1) hour for each of the perpendicular axes X, Y and Z (0.1 octave/minute). The output voltages shall remain within specification.

### 5.6 Electromagnetic Compatibility

*Table 12: EMC Requirements*

Electromagnetic Interference	FCC CFR Title 47 Part 15 Sub Part B EN55022/EN55024	Conducted B Class Radiated B Class
Harmonics	IEC61000-3-2 Class D	
Flicker	IEC61000-3-3	
ESD Susceptibility	EN-61000-4-2	±8KV by Air, ±4KV by Contact Performance Criteria B
Radiated Susceptibility	EN61000-4-3	80MHz~1000MHz (3V/m(mns) Amplitude 80% AM 1KHz

		Criteria A		
EFT/Burst	EN61000-4-4	5KHz, AC: 1KV, DC: 0,5 KV, Performance Criteria B		
Surge Voltage	EN61000-4-5	Line-to-Line: 1KV Line-to-Ground: 2KV Performance Criteria B		
Conducted Susceptibility	EN61000-4-6	0.15MHz~80MHz 3V/m Amplitude 80% AM 1KHz Performance Criteria A		
RF Conducted	EN61000-4-8	50 Hz/3A(ms)/m Performance Criteria A		
Voltage Dips and Interruptions	EN61000-4-11	30%(Voltage Dips)	10 ms	Criteria B
		60%(Voltage Dips)	100ms	Criteria C
		>95%(Voltage Dips)	500ms	Criteria C
Leakage Current	EN60950-1	3.5mA@240VAC		

## 5.7 Safety Agency Requirements

This power supply is designed to meet the following safety

**Table 13: Product Safety**

<b>Product Safety:</b>	UL,cUL	UL60950-1
	CB	IEC60950-1
	TUV	EN60950-1
	CCC	

## 6 Reliability

### 6.1 Mean Time Between Failures (MTBF)

The MTBF of the power supply shall be calculated utilizing the Part-Stress Analysis method of MIL217F. The calculated MTBF of the power supply shall be greater than 100,000 hours under the following conditions:

Full rated load; 120V AC input; Ground Benign; 25 °C

## 7. Connections

### 7.1 AC Input Connector

The AC input receptacle (CN1) shall be a 3 pins inlet. .

### 7.2 Pin Assignment of DC Connector

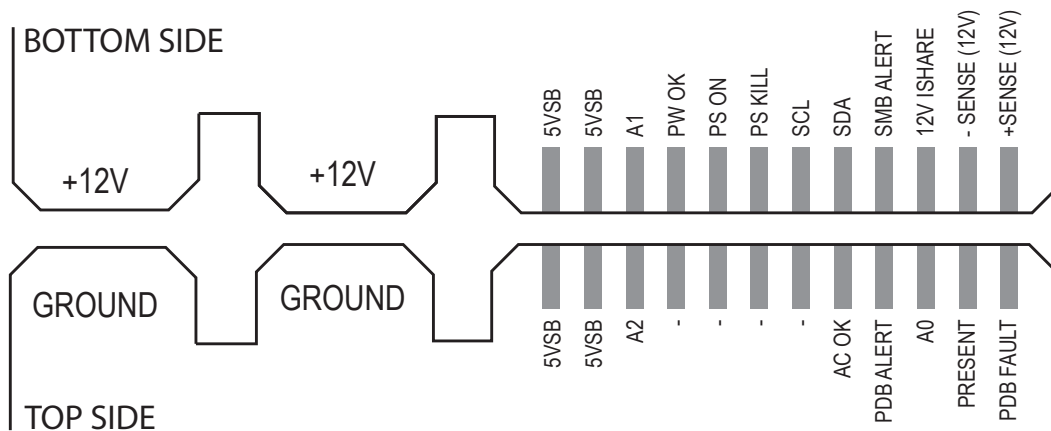
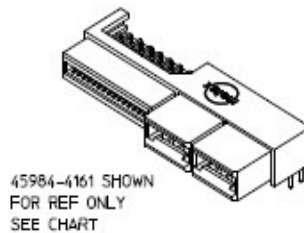

**Table 14 – Output Pin Assignment**

Pin Name	Function	System/Backplane Connection
+12V	+12V power output	TO SYSTEM 12V BUS
GND	Grounding	GND
5VSB	+5V standby power	TO SYSTEM 5VSB BUS
A0	I2C Address	Refer to Table 20
A1	I2C Address	
A2	I2C Address	
PW_OK	Power Good Output. Signal is pulled HIGH to indicate all outputs ok.	TO SYSTEM Power Good
PSON	Module PS_ON. Remote control power On/Off (Pulled LOW = POWER ON)	
PS_KILL	Activate PSU by hot-plug activity	Grounded at backplane
SCL	I2C CLOCK	TO SYSTEM I2C BUS
SDA	I2C DATA	TO SYSTEM I2C BUS
PDB-ALERT	To receive ALERT signal from system or PSU backplane, If signal is pulled LOW, the power internal fan shall be forced to run at maximum speed to improve thermal performance	This signal pin can be controlled by system, or floating via backplane.
SMB-ALERT	If PSU FAIL,FAN FAIL,OCP occurs, signal will be pulled from High to Low , PSU normal =High(TTL LEVEL)	To system related bus
12LS	12V Load Share	Connect pin to pin at backplane for each power module

Present	This pin is grounded with a 47R resistor. To indicate a power has been plugged in.	floating via backplane.
12VRS+	+12V Remote sense	TO SYSTEM 12V BUS
12VRS-	+12V negative feedback	Grounded at backplane
PDB-FAULT	To receive a FAULT signal. Power shall be shutdown if this pin is pulled HIGH.	Floating via backplane.
AC-OK	The pin will be pulled HIGH if 5VSB is ready	Floating via backplane.

## 7.3 Mating Connector

### Molex 45984 Series



## 8.LED Indicators

There will be a LED on each power module to indicate power status

**Table 15 – LED Color and Power Status**

Power Supply Status	Color
Normal(AC OK)	Green
Standby (Only +5VSB output) (AC OK)	Blinking Green
Power Fail	Red
Fan Fail	Blinking Red
AC Loss	Red

## 9.PMBus Command Codes

*Table 16 –PMBus Command Codes*

Command Code	Command Name	SMBus Transaction Type	Number of Data Bytes
19h	CAPABILITY	Read Byte	1
88h	READ_VIN(Note1)	READ WORD	2
89h	READ_IIN	READ WORD	2
8Bh	READ_VOUT	READ WORD	2
8Ch	READ_IOUT	READ WORD	2
8Dh	READ_TEMPERATURE_1	READ WORD	2
90h	READ_FAN_SPEED_1	READ WORD	2
91h	RESERVED	READ WORD	2
96h	READ_POUT	READ WORD	2
97h	READ_PIN	READ WORD	2
98h	PMBUS_REVISION	READ BYTE	1
99h	MFR_ID	R/W Block	Variable
9Ah	MFR_MODEL	R/W Block	Variable
9Bh	MFR_REVISION	R/W Block	Variable
9Eh	MFR_SERIAL	R/W Block	Variable
A0h	MFR_VIN_MIN	READ_WORD	2
A1h	MFR_VIN_MAX	READ_WORD	2
A7h	MFR_POUT_MAX	READ_WORD	2
B0h	USER_DATA_00	READ BYTE	1

Note1: If AC Input= 90V ~ 180V PMBus sent the value of 115V  
 If AC Input= 181V ~ 264V PMBus sent the value of 230V

*Table 17–MFR Meanings*

Command Code	Command Name	Meaning
99h	MFR_ID	ETASIS
9Ah	MFR_MODEL	EFRP-G507
9Bh	MFR_REVISION	A0 ~ Z9
9Eh	MFR_SERIAL	Code = 12
A0h	MFR_VIN_MIN	100VAC
A1h	MFR_VIN_MAX	240VAC
A7h	MFR_POUT_MAX	500W

### Status BYTE Message Contents

Command code = B0h (Command name = USER\_DATA\_00)

*Table 19 –Status BYTE Message Contents*

Bit Number	Status Bit Name	Meaning
7	Reserved	Default=0
6	Reserved	Default=0
5	Reserved	Default=0
4	Reserved	Default=0

3	Reserved	Default=0
2	Module Status	Inserted=0, Not inserted=1
1	PS_ON Status	PS_OFF=0, PS_ON=1
0	AC Status	AC OK=0, AC Fail=1

**Table 20 - Device address locations**

DB address A2/A1/A0	0/0/0	0/0/1	0/1/0	0/1/1	1/0/0	1/0/1	1/1/0	1/1/1
SU IPMI FRU Device	A0h	A2h	A4h	A6h	A8h	AAh	ACh	A Eh
SU PMBUS Device	B0h	B2h	B4h	B6h	B8h	BAh	BCh	BEh

## 10.Mechanical Overview

**Dimension: 50.5mm(W) x 40mm(H) x 280mm(D)**

**Weight: 1.1 Kg**

