



PRICE: \$25.00

**OPERATING MANUAL  
UNIPOWER TELECOM POWER  
CONTROL & MONITOR SYSTEM  
PCM500 SERIES**

[www.unipowertelecom.com](http://www.unipowertelecom.com)

**Manual No. PCM-800-3**

01/14/02 PCM500-Man

**© 2002 UNIPOWER Corp.  
All Rights Reserved**

**UNIPOWER Telecom, Division of UNIPOWER Corporation**

NORTH AMERICA • 3900 Coral Ridge Drive, Coral Springs, Florida 33065, USA • Tel: +1 954-346-2442 • Fax: +1 954-340-7901 • sales@unipower-corp.com  
EUROPE • Parkland Business Centre, Chartwell Road, Lancing BN15 8UE, ENGLAND • Tel: +44(0)1903 768200 • Fax: +44(0)1903 764540 • info@unipower-europe.com

# CONTENTS

<u>SECTION</u>	<u>TOPIC</u>	<u>PAGE</u>
1.0	Introduction	1
2.0	Features and Options	1
3.0	Safety Warnings	3
4.0	Warranty	3
5.0	Unpacking and Inspection	4
6.0	Specifications	4
7.0	Safety and Industry Standards	5
8.0	Front Panel Description	5
9.0	Back Panel Description	6
10.0	LED Indicators	6
11.0	Front Panel Adjustment Potentiometers	6
12.0	Description of Operation	7
13.0	Connections	7
14.0	Alarm Enabling	11
15.0	Voltage and Current Measurements	12
16.0	Battery Temperature Compensation	14
17.0	Installation and Setup	15
18.0	Final Installation and Connections	16
Appendix	Data Sheet	

# ILLUSTRATIONS

<b><u>FIGURE</u></b>	<b><u>TITLE</u></b>	<b><u>PAGE</u></b>
1	PCM500 Power Control & Monitoring System	2
2	Front and Back Panels of PCM500	2
3	PCM500 Functions	8
4	Current Measurement Connections	13
5	Test Setup for Setting Battery Overvoltage and Undervoltage	13

# UNIPOWER TELECOM POWER CONTROL & MONITOR SYSTEM

## PCM500 SERIES

### 1.0 INTRODUCTION

- 1.1 This Operating Manual should be read through carefully before installing and operating the PCM500 Series.
- 1.2 The PCM500 is a basic control and monitoring system for DC power plants. It controls up to 16 rectifiers in up to 4 shelves, precisely setting the float voltage and equalize voltage (optional) on all rectifiers simultaneously. It monitors the battery voltage and current by means of front panel test points or optionally by a front panel digital voltmeter and ammeter. See Figure 1.
- 1.3 Front panel LEDs indicate status and alarm conditions of the monitored functions. Front panel potentiometers permit easy adjustment of the various control voltages. Form C relays also indicate status and alarms.
- 1.4 The PCM500 is only one mounting position high (1.75 inches) to minimize rack space and comes with brackets that permit mounting in either a 19- or 23-inch relay rack. It can be mounted from the front of the rack with offsets every quarter-inch from front to back to align with existing rack-mounted equipment.
- 1.5 The PCM500 can be ordered configured for either 24 or 48VDC, either positive or negative plant. It is reverse polarity protected.

### 2.0 FEATURES AND OPTIONS

#### 2.1 Features

- ◆ Low Profile: One Mounting Position High: (1.75 Inches)
- ◆ 19- or 23-inch Rack Mounting
- ◆ 48 or 24VDC Versions
- ◆ Positive or Negative Polarity Plant
- ◆ Reverse Polarity Protected
- ◆ Controls & Monitors Up to 16 Rectifiers in Up to 4 Shelves
- ◆ Centralized Plant Float Voltage Adjust
- ◆ Eight LED Alarm Indicators
- ◆ Eight Form C Relay Contact Alarm Outputs
- ◆ Over & Under Battery Voltage Alarms



**Figure 1. PCM500 Power Control & Monitoring System**

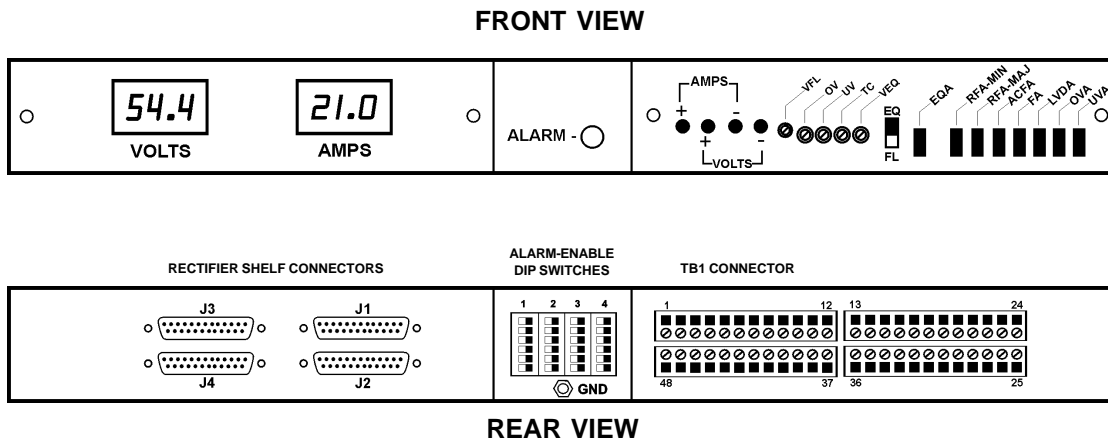

**Figure 2. Front and Back Panels of PCM500**

- ◆ Compatible with All UNIPOWER Telecom Rectifiers
- ◆ Easy Wire Connections on Rear
- ◆ Alarm Enable Switches on Back Panel

## 2.2 Options

- ◆ Centralized Plant Equalize Voltage Adjust
- ◆ Battery Temperature Compensation (with Temp. Probe)
- ◆ Meter Panel (Voltmeter & Ammeter)

## 3.0 SAFETY WARNINGS

- 3.1** This Control and Monitor System operates at voltages that could potentially be hazardous. Furthermore, inadvertent short circuiting of the system battery and/or rectifier by misconnection or other error could be harmful. This product should be handled, tested and installed only by qualified technical persons who are trained in the use of power systems and are well aware of the hazards involved.
- 3.2** When operating the PCM500 the chassis ground terminal must be connected to the system frame ground or other proper safety ground for the protection of personnel.
- 3.3** All connections to the PCM500 should be carefully checked for errors before applying power to it.
- 3.4** This equipment is intended only for installation in a “RESTRICTED ACCESS LOCATION”.

## 4.0 WARRANTY

All products of UNIPOWER Telecom, a division of UNIPOWER Corporation, are warranted for two (2) years from date of shipment against defects in material and workmanship. This warranty does not extend to products which have been opened, altered or repaired by persons other than persons authorized by the manufacturer or to products which become defective due to acts of God, negligence or the failure of customer to fully follow instructions with respect to installation, application or maintenance. This warranty is extended directly by the manufacturer to the buyer and is the sole warranty applicable. EXCEPT FOR THE FOREGOING EXPRESS WARRANTY, THE MANUFACTURER MAKES NO WARRANTY, EXPRESS OR IMPLIED, INCLUDING, BUT NOT LIMITED TO, THE WARRANTY OF MERCHANTABILITY OR FITNESS FOR A PARTICULAR PURPOSE. As the sole and exclusive remedy under this warranty, the manufacturer, at its option, may repair or replace the non-conforming product or issue credit, provided the manufacturer's inspection establishes the existence of a defect. To exercise this remedy, the buyer must contact the manufacturer's Customer Service Department to obtain a Return Material Authorization number and shipping instructions. Products returned without prior authorization will be returned to buyer. All products returned for repair must be shipped freight prepaid to UNIPOWER. If the buyer fails to fully comply with the foregoing, the buyer agrees that no other remedy (including, but not limited to, incidental or consequential damages for lost profits, lost sales, injury to person or property or any other incidental or consequential losses) shall be available to the buyer.

## 5.0 UNPACKING AND INSPECTION

- 5.1 This power control and monitoring system was carefully tested, inspected and packaged for shipment from our factory. Upon receipt of the unit it should be carefully unpacked and inspected for any damage in shipment.
- 5.2 If there is evidence of damage, do not attempt to install the unit. The freight carrier should be notified immediately and a claim for the cost of the PCM500 should be filed with the carrier for direct reimbursement. Be sure to include the model and serial number of the damaged unit in all correspondence with the freight carrier. Also save the shipping carton and packing material as evidence of damage for the freight carrier's inspection.
- 5.3 UNIPOWER Telecom will cooperate fully in case of any shipping damage investigation.
- 5.4 Always save the packing materials for later use in shipping the unit. Never ship the rectifier system without proper packing.

## 6.0 SPECIFICATIONS

### INPUTS

Voltage <sup>1</sup> .....	48VDC or 24VDC Nominal
Polarity .....	Positive or Negative Plant
Monitoring Inputs .....	Low Voltage Disconnects 1 & 2
.....	Fuse Alarms 1 through 5
.....	Battery Voltage & Current Metering <sup>2</sup>
.....	Temperature Compensation
.....	Battery Sense
.....	Battery Supply

### OUTPUTS

Control Outputs .....	Current Share
.....	Remote Adjust
Alarms, Form C Relay Contacts .....	EQA = Equalize
.....	RFA-MIN = Rectifier Failure-Minor
.....	RFA-MAJ = Rectifier Failure-Major
.....	ACFA = AC Failure
.....	FA = Fuse or Breaker Failure
.....	LVDA = Low Voltage Disconnect
.....	OVA = Battery Overvoltage
.....	UVA = Battery Undervoltage

**SAFETY STANDARDS** ..... UL1950, CSA22.2 No.950, EN60-950



float voltages.

- 8.6** Finally, in order, are the LED indicators: RFA-MIN, RFA-MAJ, ACFA, FA, LVDA, OVA and UVA which are explained in Section 10.0.

## **9.0 BACK PANEL DESCRIPTION**

- 9.1** From the left side are the four rectifier connectors J1 through J4 which control and monitor the rectifier shelves and individual rectifiers. J1 goes to rectifier shelf no. 1, J2 to shelf no. 2., etc. See Figure 2.
- 9.2** In the center of the back panel are the 24 DIP switches which enable the alarms for each rectifier, fuse or breaker panel, and low voltage disconnect. Below the switches is the chassis ground terminal.
- 9.3** On the right side is the TB1 connector with 48 terminals for connecting two-wire alarm inputs, alarm outputs and other input/output connections. These terminals accept AWG nos. 14 to 22 wire sizes.

## **10.0 LED INDICATORS**

- 10.1 Yellow LED.** Indicates controller is in the equalize voltage mode (option), determined by the front panel Equalize/Float switch.

- 10.2 Red LEDs.** These are failure alarms indicating the following:

- ◆ Rectifier Failure Alarm-Minor (a single rectifier failure)
- ◆ Rectifier Failure Alarm -Major (two or more rectifier failures)
- ◆ AC Input Failure (on any rectifier)
- ◆ Failure on any Fuse or Circuit Breaker in a distribution panel
- ◆ Failure on one or both Low Voltage Disconnects
- ◆ Battery Overvoltage
- ◆ Battery Undervoltage

## **11.0 FRONT PANEL ADJUSTMENT POTENTIOMETERS**

There are five front panel adjustment potentiometers:

- ◆ **VFL:** Float Voltage set (12 turns)
- ◆ **OV:** Battery Overvoltage set (single turn)
- ◆ **UV:** Battery Undervoltage set (single turn)
- ◆ **TC:** Temperature Compensation set (single turn)
- ◆ **VEQ:** Equalize Voltage set (single turn)

Note that Temperature Compensation and Equalize Voltage are options that must be ordered.

## **12.0 DESCRIPTION OF OPERATION**

- 12.1** See Figure 3. The PCM500 controls and monitors up to four rectifier shelves containing up to four rectifiers each. This is accomplished by means of the four connectors J1 through J4 which connect to rectifier shelves one through four, respectively. Through these connections the PCM500 controls the rectifier output voltage which is preset by the VFL (float voltage) and optionally by VEQ (equalize voltage) adjustment potentiometers. The front panel EQ/FL switch puts the rectifier outputs in either the equalize or float mode.
- 12.2** The PCM500 also monitors the AC input and DC output of each of the rectifiers and gives an LED warning and Form C relay contact alarm in case of failure of any one.
- 12.3** The PCM500 also monitors for alarms up to two low voltage disconnect panels and up to five fuse panels or circuit breaker panels. The alarm outputs are Form C relay contacts which can be used for remote or local system alarms. The PCM500 has inputs from the low-voltage disconnect panels and the fuse panels or circuit breaker panels.
- 12.4** Other alarm outputs are for battery overvoltage and battery undervoltage. These are also Form C relay contacts.
- 12.5** Battery voltage and current are also monitored by the PCM500. They are read either by the optional front panel voltmeter and ammeter or from the front panel test points. An external shunt is required for current measurement.

## **13.0 CONNECTIONS**

- 13.1 Rectifier Connections.** See Figure 2. Rectifier connections are made to the J1 through J4 receptacles, standard 25-pin subminiature D connectors (Positronic No. SD25F0S500X with FC7520D pins). The mating plug is a Positronic SD25M0000Z with MC7520D pins. These connectors are identical to and automatically mate with those on all UNIPOWER Telecom rectifier shelves: Mercury (RMF), Magellan (RMM, RMP), Vanguard (RVN) and Ranger (RRS). The table following gives the connections by pin number to the rectifier shelves and rectifiers.

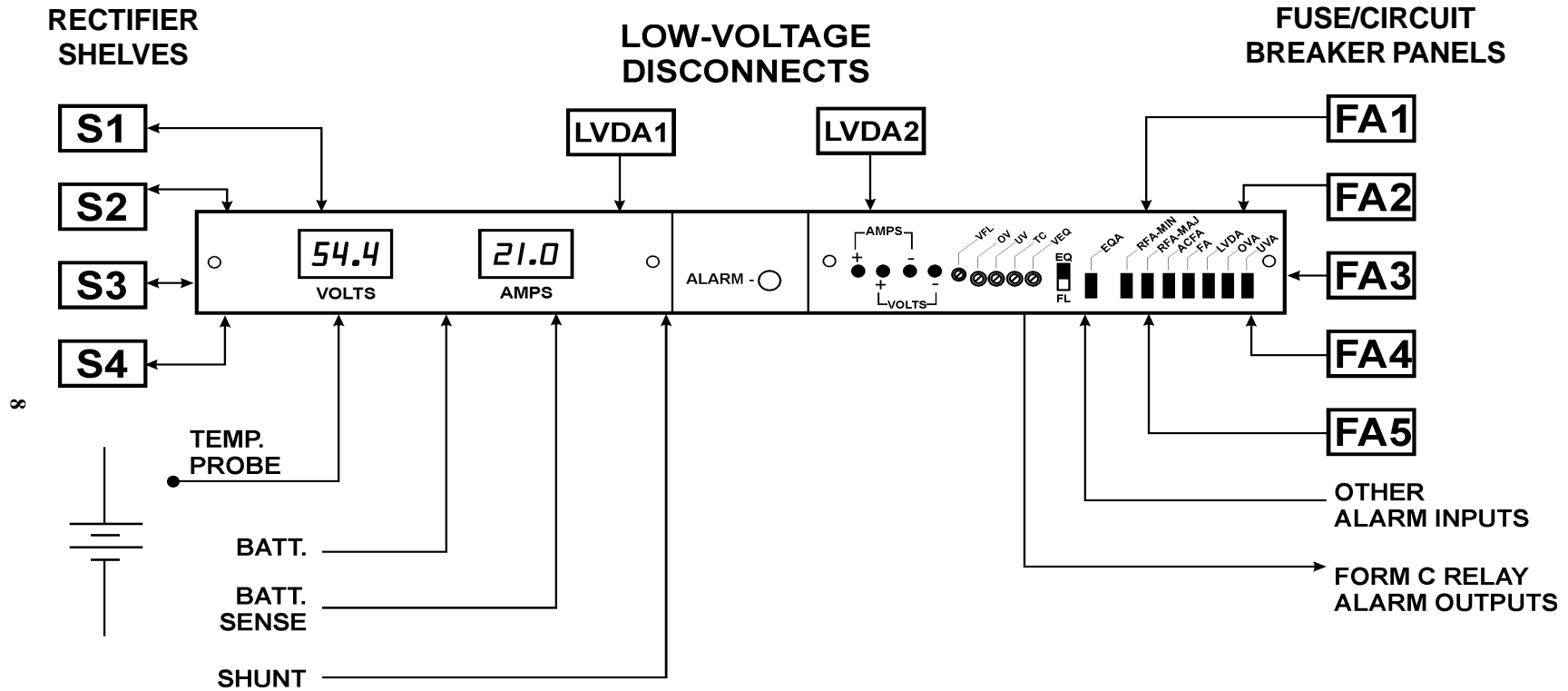
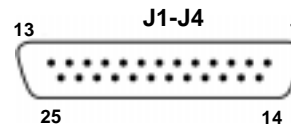

Figure 3. PCM500 Functions

J1-J4 SIGNAL CONNECTORS			
PIN	FUNCTION	PIN	FUNCTION
1	NC	14	AC Good-1
2	NC	15	DC Good-1
3	NC	16	AC Good-2
4	NC	17	DC Good-2
5	NC	18	AC Good-3
6	NC	19	DC Good-3
7	NC	20	AC Good-4
8	NC	21	DC Good-4
9	NC	22	Signal Common
10	Current Share	23	-Sense
11	+ Sense	24	Remote Adjust-1
12	Remote Adjust-2	25	Remote Adjust-3
13	Remote Adjust-4		



**NOTE:** J1-J4 Connectors are for rectifier shelves 1-4 respectively. Numbers following functions refer to rectifier modules 1-4 in each shelf. NC=No connection.

**13.2 Alarm and Other Input/Output Connections.** See Figure 2. These connections are made to TB1 which is a 48-pin Euro-style terminal block. There are seven alarm inputs (14 terminals), eight Form C relay contact alarm outputs (24 terminals) and 10 terminal connections for other input/output (I/O) connections. These connections are specified in the tables following.

**TB1 TERMINAL CONNECTIONS**

**ALARM INPUTS**

FUNCTION	TERM NOS.
LVDA1 IN	1 & 48
LVDA2 IN	2 & 47
FA1 IN	3 & 46
FA2 IN	4 & 45
FA3 IN	5 & 44
FA4 IN	6 & 43
FA5 IN	7 & 42

**ALARM OUTPUTS**

FUNCTION	TERM NO.	FUNCTION	TERM NO.
EQA (NC)	13	FA (NC)	25
EQA (C)	14	FA (C)	26
EQA (NO)	15	FA (NO)	27
OVA (NO)	16	ACFA (NC)	28
OVA (C)	17	ACFA (C)	29
OVA (NC)	18	ACFA (NO)	30
RFA-MIN (NO)	19	RFA-MAJ (NC)	31
RFA-MIN (C)	20	RFA-MAJ (C)	32
RFA-MIN (NC)	21	RFA-MAJ (NO)	33
LVDA (NO)	22	UVA (NC)	34
LVDA (C)	23	UVA (C)	35
LVDA (NC)	24	UVA (NO)	36

**OTHER I/O**

FUNCTION	TERM NOS.
I+ (IN)	41
I- (IN)	8
TC (IN)	9 & 40
B+ (IN)	10
B- (IN)	11
CS (OUT)	12
BS+ (IN)	39
BS- (IN)	38
RA (OUT)	37

Inputs on terminals 1-7 and 42-48 are from relay contacts on low voltage disconnect panels and fuse/breaker panels. An “open” at these terminals indicates an alarm.

Outputs on terminals 13-36 are Form C relay contact alarms for the functions given. “Normally Closed” (NC) means a “short” between this terminal and the Common (C) terminal when the function is operating properly with power applied. “Normally Open” (NO) means an “open” between this terminal and the Common (C) terminal when the function is operating properly with power applied.

**13.3 Abbreviations/Acronyms.** These are used in the previous tables and are defined in the following table.

ACRONYM	DESCRIPTION
LVDA	Low Voltage Disconnect Alarm
FA	Fuse/Circuit Breaker Alarm
I+, I-	Meter Shunt
TC	Temperature Compensation (from probe)
B+, B-	Battery (from rectifier bus)
CS	Current Share (to rectifier shelves)
EQA	Equalize Alarm
OVA	Battery Overvoltage Alarm
RFA-MIN	Rectifier Failure Alarm - Minor (single rectifier failure)
ACFA	AC Failure Alarm
RFA-MAJ	Rectifier Failure Alarm - Major (two or more rectifier failures)
UVA	Battery Undervoltage Alarm
RA	Remote Adjust (to rectifier shelves)
BS+, BS-	Battery Sense

**13.4 Explanation of Other I/O Connections.** Most of the connections to TB1 are alarm inputs and outputs. The “Other I/O” connections are various analog type connections.

**13.41 I+ and I- Input.** These are the + and - connections from a meter shunt that is used to measure battery current. See Section 15.3 on “Current” for further details.

**13.42 TC Input.** This is the optional temperature compensation input from the temperature compensation probe that comes with this option. The probe is used to measure battery temperature which is used to control the output of the rectifier. See Section 16.0 on “Battery Temperature Compensation”. There is no polarity reference on this.

**13.43 B+ and B- Input.** These connections are to the common rectifier output bus which is used to provide power to operate the PCM500

circuitry.

**13.44 CS Output.** This is the current share connection to the four rectifier shelves and is used only if additional rectifier shelves are added to the system.

**13.45 BS+ and BS- Inputs.** These are battery sense inputs to PCM500 and are connected to the common rectifier bus near the battery but on the rectifier side of any battery disconnect or LVD circuit.

## 14.0 ALARM ENABLING

**14.1 Alarm-Enable Switches.** These switches are located at the center of the back panel. As shown following there are four columns with six each DIP switches. The columns and rows are numbered.

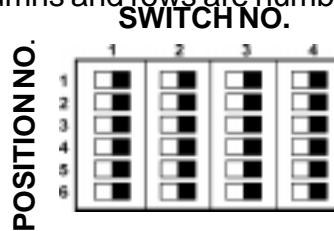

Each switch controls one of the alarm functions. The PCM500 comes with all alarm functions disabled, with the switches in the left position. Moving a switch to the right enables that function.

**14.2 Alarm Functions.** There are 24 separate alarm functions controlled by the Alarm-Enable switches. Only those functions used should be enabled; otherwise false alarms will be created. The first 16 functions are rectifier/alarms. Provision is made for shelf number and rectifier number for up to four shelves with up to four rectifiers each. SR stands for shelf/rectifier. As shown in the following table the shelf no. and rectifier no. correspond to the switch no. and position no., respectively. Thus switch no. 2, position no. 3 (2,3) enables the shelf no. 2, rectifier no. 3 alarm (SR23). When the proper rectifier alarm-enable switches are set, if any one rectifier fails the RFA-MIN (Rectifier Failure-Minor) red LED will come on, and the RFA-MIN Form C relay will change state. If more than one rectifier fails the RFA-MAJ (Rectifier Failure-Major) red LED will come on and the RFA-MAJ Form C relay will change state.

### ALARM-ENABLE DIP SWITCHES

POS. NO.	SW. NO.1 FUNCTION	SW. NO.2 FUNCTION	SW. NO.3 FUNCTION	SW. NO.4 FUNCTION
1	SR11	SR21	SR31	SR41
2	SR12	SR22	SR32	SR42
3	SR13	SR23	SR33	SR43
4	SR14	SR24	SR34	SR44
5	FA1	FA3	FA5	LVDA1
6	FA2	FA4	NC	LVDA2

The FA1 through FA5 alarms function for up to five fuse or circuit breaker distribution panels. If any fuse or circuit breaker on any panel opens, this will cause the FA (Fuse or Circuit Breaker Alarm) red LED to come on and the FA Form C relay to change state. The LVDA1 and LVDA2 alarm-enable switches are for one or two Low Voltage Disconnect panels. If either one of these experience a disconnect, the LVDA (Low Voltage Disconnect Alarm) red LED will come on and the LVDA Form C relay will change state.

## 15.0 VOLTAGE AND CURRENT MEASUREMENTS

**15.1 Meters and Test Points.** The meter panel option (Option MP) provides a digital voltmeter and ammeter on the left front panel to monitor the battery voltage and current.

**15.2 Voltage.** The digital voltmeter reads battery voltage directly, to tenths of a volt. The “volts” test points on the right front panel also permit direct external measurement of the battery voltage when the MP option is not taken.

**15.3 Current.** The digital ammeter is scaled at the factory to read amperes based on a 50 millivolt external shunt and corresponding internal scale factor which must be chosen at the time of ordering. The following table gives the ammeter shunt rating and ordering suffix code for the correct meter setting at the factory. The external shunt **must be connected with correct polarity** across the I+ and I- input terminals (TB1 terminals 41 and 8, respectively). See Figure 4 and Section 13.2.

**External 50mV Shunt**

CODE	AMMETER SHUNT RATING	CODE	AMMETER SHUNT RATING
25	25A	250	250A
30	30A	300	300A
50	50A	500	500A
75	75A	1000	1000A
100	100A	1500	1500A
150	150A	2000	2000A
200	200A		

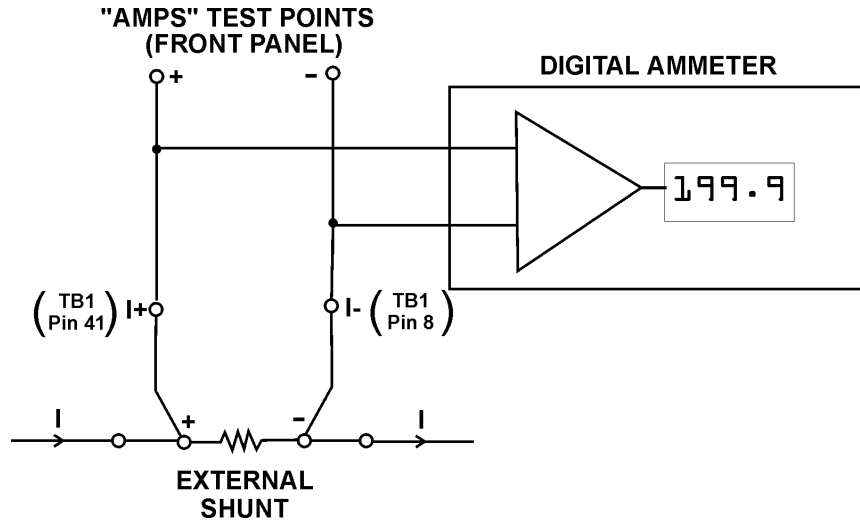

**Figure 4. Current Measurement Connections**

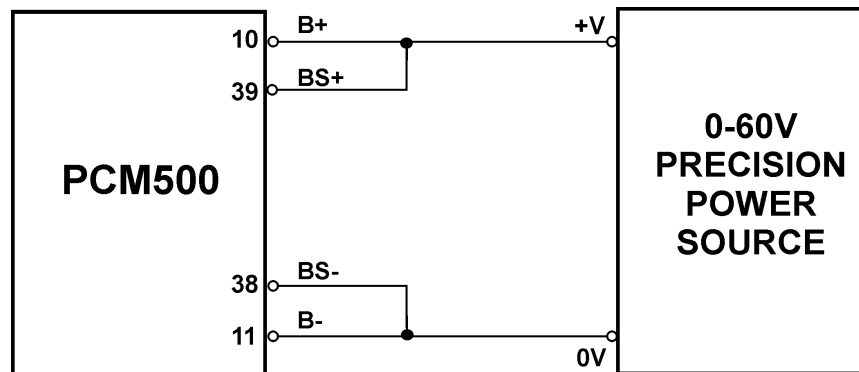

**Figure 5. Test Setup for Setting Battery Overvoltage and Undervoltage**

This table shows that, for example, a 50mV, 100A shunt is the shunt resistance that produces 50mV for a 100A full-scale current. In this case the shunt resistance is  $50\text{mV} \div 100$ , or 0.5 milliohm. The shunt rating is always the full-scale current that produces 50mV across the shunt.

The 3 ½ digit ammeter resolves current readings to 0.1A over the 25A to 200A full-scale range. From 250A to 2000A full scale, the meter resolves current to the nearest ampere. Overall accuracy is moderate, generally within  $\pm 5\%$ . Current may also be measured at the “AMPS” test points by using a 50mV full scale voltmeter. The external shunt must be also used for this measurement. The actual current must then be determined by multiplying the meter reading in millivolts by the full scale shunt current divided by 50.

## 16.0 BATTERY TEMPERATURE COMPENSATION

- 16.1** The temperature compensation option (Option TC) comes with a temperature probe and 20-foot cable. The probe is a thermistor which is connected to TB1 pins 9 and 40. There is no polarity for this connection. The probe is used to monitor the temperature of the battery and adjust the rectifier output voltage accordingly. As battery temperature increases, rectifier output voltage decreases.
- 16.2** The change in output voltage with temperature is  $-3\text{mV}/^\circ\text{C}$  per battery cell, centered at  $25^\circ\text{C}$ . For example, for a  $+10^\circ\text{C}$  temperature change from  $25^\circ\text{C}$  with the rectifier charging a 48V battery, the change in the rectifier output voltage would be:

$$\frac{48}{2} = 24 \text{ cells}$$

$$\Delta V = 24 \text{ cells} \times 10^\circ\text{C change} \times (-3\text{mV}) = -720\text{mV} = -0.72\text{V}$$

- 16.3** The probe can be located in several possible places: right on the battery to detect the battery temperature; near the battery in free air to detect the local ambient temperature; or on the power plant metal frame near the battery. For the procedure on calibrating this temperature compensation system, see Section 17.6.
- 16.4** If the TC probe is either opened or shorted, the rectifier outputs revert to the float voltage.

## 17.0 INSTALLATION AND SETUP

- 17.1 Mounting.** The PCM500 can be mounted in either 19- or 23-inch racks by using the appropriate brackets. Mount it from the front of the rack using the correct offsets to align with existing rack-mounted equipment. The bracket offsets are every quarter-inch from front to back.
- 17.2 Setting the Battery Overvoltage.** Set a 0-60VDC precision power source or variable DC power supply with an output voltmeter to approximately 55V. Turn the supply off and connect it to the PCM500 TB1 terminals as shown in Figure 4. Turn the power supply back on and set the output voltage to the desired voltage for the battery overvoltage alarm. Then adjust the front panel OV potentiometer to the trip point where the OVA (overvoltage alarm) red LED just barely turns on.
- 17.3 Setting the Battery Undervoltage.** Using the same setup, set the 0-60V supply to the desired voltage for the undervoltage alarm. Adjust the front panel UV potentiometer to the trip point where the UVA (undervoltage alarm) red LED just turns on. Turn off the 0-60V supply and disconnect it.
- 17.4 Setting the Battery Float Voltage.** Connect a single rectifier to the PCM500 by means of J1. Set the front panel EQ/FL switch to FL (float, down position). Connect the B+ input (TB1 term. 10) and BS+ input (TB1 term. 39) to the rectifier positive output. Connect the B- input (TB1 term. 11) and BS- input (TB1 term. 38) to the rectifier negative output. Turn on the rectifier and read the rectifier output voltage on the front panel voltmeter (option) or digital voltmeter connected to the “volts” test points. Adjust the VFL (float voltage) multi-turn potentiometer to the desired float voltage as read on the voltmeter.
- 17.5 Setting the Battery Equalize Voltage (Option).** Continuing from above, set the EQ/FL switch to EQ (equalize, up position). The EQA (equalize alarm) yellow LED should turn on. Adjust the VEQ (equalize voltage) potentiometer to the desired equalize voltage as read on the voltmeter.
- 17.6 Setting the Temperature Compensation Voltage (Option).**
- 17.6.1** Make sure that the float voltage was set with the temperature probe disconnected.
- 17.6.2** Before connecting the temperature probe, record the float voltage to three digits.

- 17.6.2 Connect the temperature probe to terminals 9 and 40 of TB1.
- 17.6.3 With the temperature probe at approximately 25°C ambient temperature, adjust the front panel TC potentiometer until the rectifier output voltage as read on the front panel voltmeter or external voltmeter is exactly the same as the previously recorded float voltage.

**17.7 Checking the Alarm Functions.** With the above rectifier connected to the Shelf 1, Rectifier 1 position, check the alarm functions as follows.

- 17.7.1 Move the SR11 Alarm-Enable DIP Switch to the enable (right) position. The red LED alarm should not turn on.
- 17.7.2 Move the SR22 rectifier DIP switch to the enable (right) position. The RFA-MIN (rectifier failure alarm-minor) red LED should turn on; the ACFA (AC failure alarm) red LED should also turn on. Move the SR22 switch back to disable (left). Move the SR33 DIP switch to the enable position. The RFA-MIN and ACFA red LEDs should again turn on. Move the SR44 DIP switch to the enable position. The RFA-MAJ (rectifier failure alarm-major) red LED should turn on and ACFA red LED should remain on. The RFA-MIN red LED should turn off.
- 17.7.3 Move the FA1 (fuse/circuit breaker alarm) DIP switch to the enable position. The FA red LED should turn on.
- 17.7.4 Move the LVDA1 (low-voltage disconnect alarm) DIP switch to the enable position. The LVDA red LED should turn on.
- 17.7.5 Move all DIP switches back to their disable (left) positions.

## 18.0 FINAL INSTALLATION AND CONNECTIONS

- 18.1 To complete the installation, the following connections must be made. Do these with the rectifier(s) off and no connection to the battery yet.
- 18.2 Connect the rectifier shelves to be used to the J1 to J4 connectors on the back of the PCM500. Use up the positions in sequence, one through four. Likewise, fill the shelves with rectifiers in sequence, leaving any blanks at the end of the sequence. All UNIPOWER Telecom rectifier connections are

compatible with the PCM500 J1-J4 connectors. Compatible cables are available from UNIPOWER Telecom; contact the factory. If another manufacturer's rectifiers and shelves are used, they must be properly connected, pin for pin, to be compatible with J1-J4 as shown in the "Signal Connectors" table. The AC Good and DC Good functions must give a TTL HI or Open for a fault, and the remote adjust input range must fall within 0V to +5V.

- 18.3** Set the appropriate Alarm-Enable DIP switches to the enable (right) position for the alarm functions used. All others must remain in the disable (left) position.
- 18.4** Make all the Alarm Input connections to TB1 from the fuse/circuit breaker panels and the low-voltage disconnect panels. These inputs must be "normally closed" but go to an "open" for an alarm condition. Numbers 14 to 22 AWG wire size may be used on all TB1 terminals.
- 18.5** Make all Alarm Output connections to TB1 for the alarm functions used. These connections (terminals 13-36) are Form C relay outputs. "Normally Closed" (NC) means a "short" between this terminal and the "common" (C) terminal when the function is operating properly with power applied. "Normally Open" (NO) means an "open" between this terminal and the "Common" (C) terminal when the function is operating properly with power applied. The only exception to this is the EQA (equalize alarm) function; this function is defined as "Normal" when the EQ/FL switch is in the FL (float) position. An alarm is created when the switch is in the EQ (equalize) position; the EQA yellow LED also turns on.
- 18.6** Determine which side of the shunt goes to the battery floating terminal. Do not connect to battery yet. Connect leads from each side of the shunt, **with proper polarity**, to the TB1 shunt input terminals, I+ and I- (terminals 41 and 8 respectively).
- 18.7** If the battery temperature compensation is used, connect the leads from the probe to TB1 TC terminals 9 and 40. There is no polarity to this connection. The probe should be installed on or near the battery as discussed in Section 16.3.
- 18.8** With the rectifiers still off, connect the B+ and B- inputs to TB1 (terminals 10 and 11 respectively) to the positive and negative common rectifier distribution buses.

- 18.9** Connect the BS+ and BS- (battery sense) inputs to (TB1 terminals 39 and 38 respectively) to the positive and negative sides of the battery, but on the rectifier side of any battery disconnects or circuit breakers.
- 18.10** The PCM500 is now ready to operate. The shunt should now be connected to the battery. After this is done the rectifier shelves should be turned on.