



OPERATING MANUAL

INVO Series

5KVA INVERTER / CHARGER INVC4850H – 48V Battery INVC9650H – 96V Battery

WWW.UNIPOWERCORP.COM

Manual No. INVO-1
08/11 invo-man

© 2011 UNIPOWER Corp.
All Rights Reserved

UNIPOWER Corporation

NORTH AMERICA • 3900 Coral Ridge Drive, Coral Springs, Florida 33065, USA • Tet: +1 954-346-2442 • Fax: +1 954-340-7901 • sales@unipower-corp.com
EUROPE • Parkland Business Centre, Chartwell Road, Lancing BN15 8UE, ENGLAND • Tet: +44(0)1903 768200 • Fax: +44(0)1903 764540 • telecom@unipower-europe.com

Contents

<i>ABOUT THIS MANUAL</i>	4
Purpose	4
Scope	4
<i>IMPORTANT SAFETY INSTRUCTIONS</i>	4
General Precautions	4
Personal Precautions	5
<i>INSTALLATION</i>	6
Unpacking and Inspection	6
Basic Configuration	6
Batteries	7
Battery Cable Size	7
DC Disconnect and Over-Current Protection	8
Battery Cable Connection	8
AC Cable Size	9
AC Connections	9
<i>OPERATION</i>	11
Front Panel Controls and LCD Indicators	11
Power ON/OFF	11
Configuration Switch	11
LCD Indicator	12
Battery Charger	13
Circuit Breaker	13
<i>SPECIFICATIONS</i>	14
TROUBLESHOOTING	18

ABOUT THIS MANUAL

Purpose

The purpose of this manual is to provide explanations and procedures for installation, operation and troubleshooting. This manual should be read carefully before installation and operation.

Please retain this manual for future reference.

Scope

This document defines the functional requirements of the inverter/charger, which is intended for worldwide use in electronic data processing applications. All manuals are applicable under all operating conditions when installed in the End Use system, unless otherwise stated.

IMPORTANT SAFETY INSTRUCTIONS



WARNING: This chapter contains important safety and operating instructions. Read and keep this User Guide for future reference.

General Precautions

1. Before using the inverter/charger, read all instructions and cautionary markings on:
The inverter/charger.
The batteries.
All appropriate sections of this manual.
2. **CAUTION** - To reduce risk of injury, charge only deep-cycle lead acid type rechargeable batteries. Other types of batteries may burst, causing personal injury and damage.
3. Do not expose the inverter/charger to rain, snow or liquids of any type. The inverter/charger is designed for indoor use only. Protect the inverter/charger from splashing if used in vehicle applications.
4. Do not disassemble the inverter/charger. Take it to a qualified service center when service or repair is required. Incorrect re-assembly may result in a risk of electric shock or fire.
5. To reduce risk of electric shock, disconnect all wiring before attempting any maintenance or cleaning. Turning off the inverter/charger will not reduce this risk.
6. **WARNING: WORKING IN THE VICINITY OF A LEAD ACID BATTERY IS DANGEROUS. BATTERIES GENERATE EXPLOSIVE GASES DURING NORMAL OPERATION.**

Provide ventilation to outdoors from the battery compartment. The battery enclosure should be designed to prevent accumulation and concentration of hydrogen gas in “pockets” at the top of the compartment. Vent the battery compartment from the highest point. A sloped lid can also be used to direct the flow to the vent opening location.

7. **NEVER** charge a frozen battery.

8. No terminals or lugs are required for hook-up of the AC wiring. AC wiring must be no less than 10 AWG gauge copper wire and rated for 75°C or higher. Battery cables must be rated for 75°C or higher and should be no less than as stated in table 1. Crimped and sealed copper ring terminal lugs with a 5/16 hole should be used to connect the battery cables to the DC terminals of the inverter/charger. Soldered cable lugs are also acceptable.
9. Be extra cautious when working with metal tools on, or around batteries. The potential exists to drop a tool and short-circuit the batteries or other electrical parts resulting in sparks that could cause an explosion.
10. No AC or DC disconnects are provided as an integral part of this inverter/charger. Both AC and DC disconnects must be provided as part of the system installation. See INSTALLATION section of this manual.
11. No over current protection for the battery supply is provided as an integral part of this inverter/charger. Over current protection of the battery cables must be provided as part of the system installation. See INSTALLATION section of this manual.
12. **GROUNDING INSTRUCTIONS** - This inverter/charger should be connected to a grounded permanent wiring system. For most installations, the Ground Lug should be bonded to the grounding system at **ONLY** one in the system. All installations should comply with all national and local codes and ordinances.

Personal Precautions

1. Someone should be within range of your voice to come to your aid when you work near batteries.
2. Have plenty of fresh water and soap nearby in case battery acid contacts skin, clothing, or eyes.
3. Wear complete eye protection and clothing protection. Avoid touching eyes while working near batteries. Wash your hands when done.
4. If battery acid contacts skin or clothing, wash immediately with soap and water. If acid enters eyes, immediately flood eyes with running cool water for at least 15 minutes and get medical attention immediately.
5. Baking soda neutralises lead acid battery electrolyte. Keep a supply on hand in the area of the batteries.
6. **NEVER** smoke or allow a spark or flame in the vicinity of a battery or generator.
7. Be extra cautious when working with metal tools on and around batteries. The potential exists to short-circuit the batteries or other electrical parts which may result in a spark that could in turn cause an explosion.

Remove personal metal items such as rings, bracelets, necklaces, and watches when working with a battery. A battery can produce short-circuit currents high enough to weld a ring or the like to metal, causing severe burns.

If a remote or automatic generator start system is used, disable the automatic starting circuit and/or disconnect the generator from its starting battery while servicing to prevent accidental starting during servicing.

INSTALLATION

Unpacking and Inspection

Carefully unpack the inverter/charger from its shipping carton.

Verify all of the items listed below are present. Please call customer service if any items are missing:

- The Inverter/Charger
- 1 DC red cable
- 1 DC black cable
- 1 User's manual (this document)

Basic Configuration

The following illustration shows the basic utility backup application for the Invo Series 5KVa inverter/charger.

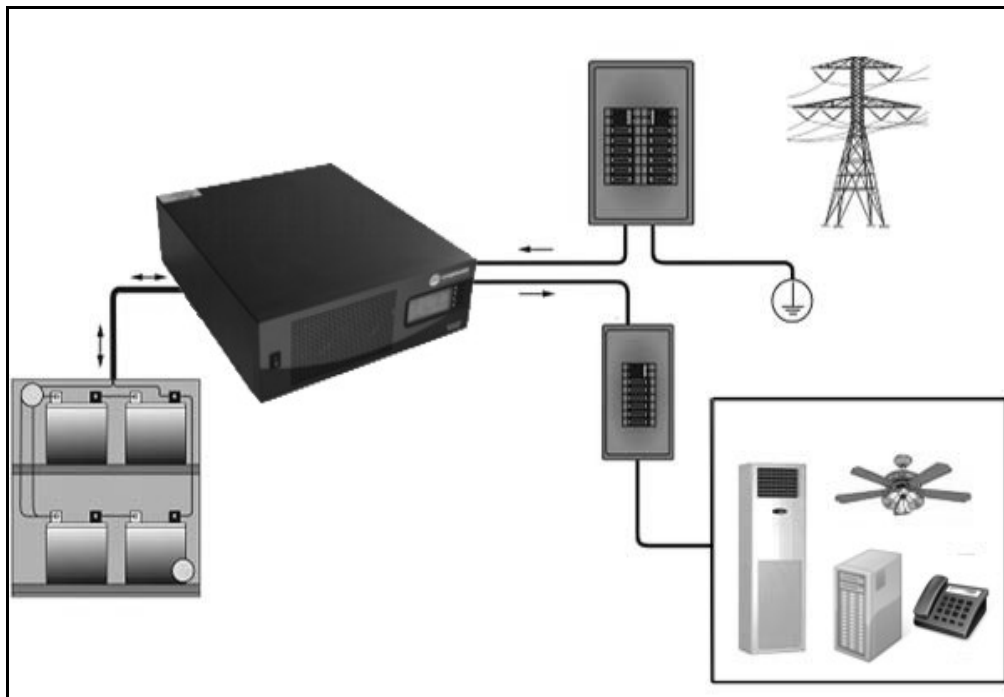

Figure 1 - Utility Backup

For other application configurations such as renewable energy systems using solar or wind power please contact sales.

The Invo Series 5KVA Inverter/Charger can feed almost any kind of appliance including those with motor characteristic, e.g. fluorescent lights, fans, refrigerators and air conditioners.

Note: Appliances such as air conditioners often require at least 3 minutes to restart after a short-term power outage (time is required to balance the refrigerant gas in inside circuit). In order to protect your air conditioner, please consult the manufacturer whether they have already provided a time delay function before installing the INVO Series inverter; otherwise, the inverter will trigger an overload fault and shut off its output to protect your appliance. Even so there is some risk of damage to the air conditioner for which UNIPOWER cannot be held responsible.

Batteries

The INVO inverter/charger supports either a 48 volt or a 96 volt battery bank depending on the model. Please refer to figure 2 for wiring the battery correctly. Before proceeding, ensure you have appropriate size batteries for your application. The INVO inverter/charger can be used with flooded lead-acid, or sealed GEL/AGM lead-acid batteries so ensure that your batteries are in one of these categories.

The battery must be wired to match the inverter/chargers DC input voltage specifications. We recommend that the battery capacity not smaller than 100AH (INVC4850H) / 50AH (INVC9650H).

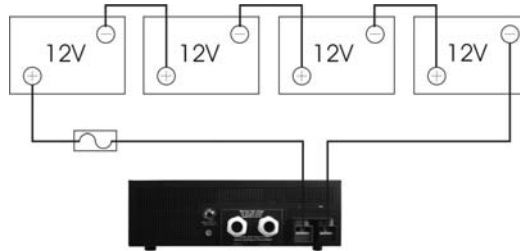

Figure 2.1 - INVC5048H battery string wiring

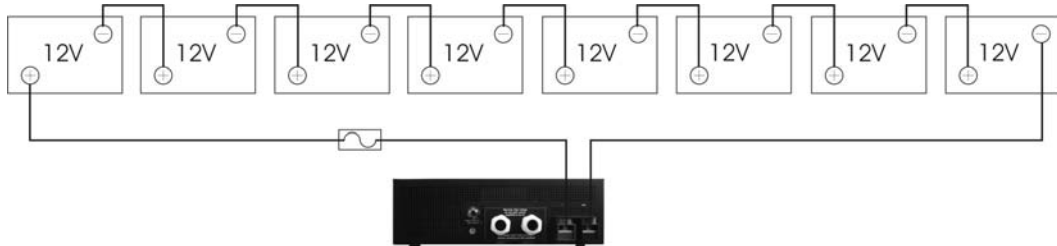

Figure 2.2 - INVC5096H battery string wiring

Battery Cable Size

The following table shows minimum recommended battery cable size. Be sure the cable you select is no smaller than this.

Model Number	Typical DC Current	Cable length 1~3m per pole	Battery Terminal Torque value
INVC5048H	100A	4 AWG	10~15 Nm
INVC5096H	50A	6 AWG	10~15 Nm

Table 1 - Minimum recommended battery cable size

DC Disconnect and Over-Current Protection

For safety and to comply with regulations, battery over-current protection and disconnect devices are required. Fuses and disconnects must be sized to protect the DC cable size used, and must be rated for DC operation. Do not use devices rated only for AC service – they will not function properly.

Note that some installation requirements may not require a disconnect device, although over-current protection is still required.

Battery Cable Connection

Observe Battery Polarity! Place the ring terminal of the DC cable over the bolt and directly against the inverter/charger's battery terminal. Tighten the M8 screw to 5-8 Nm. **Do not place anything between the flat part of the Backup terminal and the battery cable ring terminal or overheating may occur. DO NOT APPLY ANY TYPE OF ANTI-OXIDANT PASTE TO TERMINALS UNTIL AFTER THE BATTERY CABLE WIRING IS TORQUED!!**

Figure 3 below illustrates the proper method to connect the battery cables to the inverter/charger terminals.



WARNING: Shock Hazard. Installation must be performed with care for the high battery voltage in series.



Caution!! Do NOT place anything between battery cable ring terminals and terminals on the inverter. The terminal screw is not designed to carry current.

Apply Anti-oxidant paste **AFTER** terminals have been tightened.

Verify that the cable lugs are flush with the battery terminals.
Tighten battery cables to terminals (10~15 Nm).

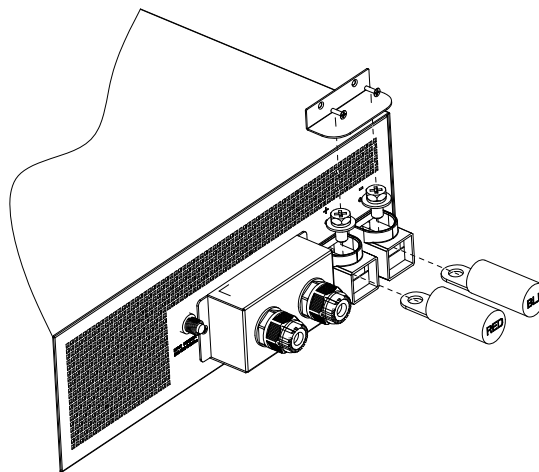

Figure 3 - Battery Cable Connections to inverter/charger

AC Cable Size

Before wiring the input and output of the inverter, refer to table 2 for minimum recommended cable sizes and torque values.

Model Number	AC Input	AC Output	Torque value
INVC5048H	10AWG	10AWG	1.2~1.8 Nm
INVC5096H	10AWG	10AWG	1.2~1.8 Nm

Table 2 - Min recommended cable size, torque value for AC wiring

AC Connections

Installation should be done only by a qualified electrician. Consult the local codes for the proper wire sizes, connectors and conduit requirements.

On the left of rear chassis is the AC hardwire cover. A six-way terminal block is provided to make the AC connections. The terminal block is used to hardwire the AC input, AC output, and ground. The National Electrical Code requires that an external disconnect switch be used in the AC input wiring circuit. The AC breakers in a sub panel will meet this requirement.

1. Disconnect the inverter/charger from the battery either by turning off the battery switch or removing the battery cables from the battery. Turning off the inverter/charger does not constitute disconnecting from the battery.
2. Feed the wires through the cable clamp and AC cover. See Figure 4.

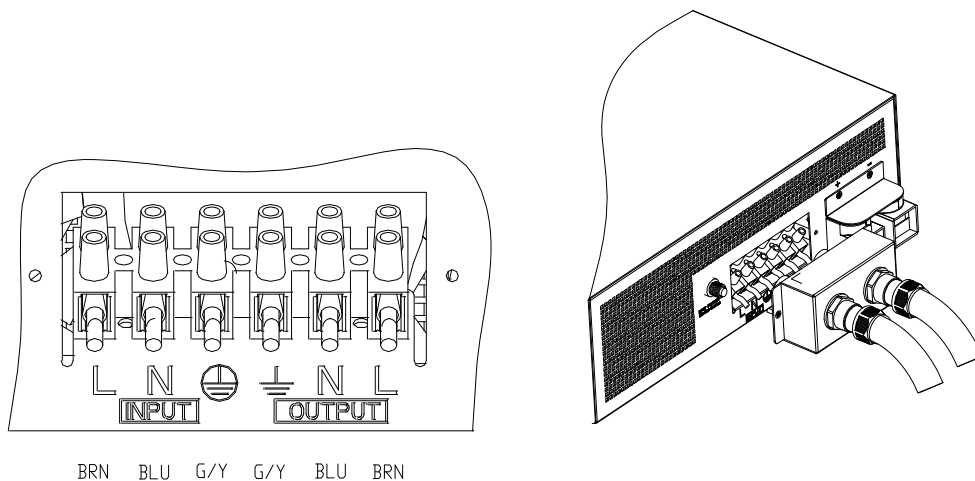

Figure 4 - AC Cable Connections to inverter/charger

3. Following the wiring guide located in the AC wiring compartment as Figure 4, connect the GND (green/yellow), Line (brown), and neutral (blue) wires from the AC input (utility, generator, etc.) to the terminal block.



Caution!! Be sure that AC source is disconnected before attempting to hardwire it to the inverter/charger.

4. Connect the AC Line output wiring to the terminal marked AC Line (output) following the wiring guide inside the compartment. Connect the AC neutral out to the AC neutral out terminal. Torque the wires into the terminal block.
5. Use the two M3 screws to lock the AC cover.
6. Tighten the clamps on the AC cable jackets (not the individual wires) to provide strain relief for the connections.

OPERATION

Front Panel Controls and LCD Indicators

Figure 5 shows the controls and indicator lights on the front of the INVO Series inverter/charger. They control and provide information in both inverter and battery charging modes of operation.



Figure 5 - Front Panel

Power ON/OFF

Located on the left of the panel is the **ON/OFF Switch**. Once the inverter/charger has been properly installed and the batteries connected, press this switch to the ON position to switch on the inverter/charger.

Important Note: INVO Series has a fail-safe system that will not allow it to switch on unless batteries are connected and the charge voltage of the batteries is above 42V for the INV5048H and 82V for the INV5096H.

Configuration Switch

On the right of panel are the 4 configuration switches which setup the inverter/charger operation parameters. See table 3 for details.





Switch	Function	Description
	up	Move up to pre-select
	down	Move down to pre-select
	configuration	Enter configuration mode, and turn page
	enter	Enter to confirm

Table 3 - configuration button function

After you press configuration button and enter configuration mode, there is a total of 4 configuration pages. Change the page by pressing the configuration button again.

Page	Description	Selectable option
1	Input range	Normal / Generator / Wide Range
2	Output range	220V / 230V / 240V
3	Battery type	AGM / GEL / FLOODED
4	Charger current	35A/20A(INVC5048H), 20A/10A(INVC5096H)
5	Saver mode	ON/OFF

Note: The 220v and 240v output function is reversed for further feature.

Table 4 - configuration button function

LCD Indicator

The LCD display provides system status, and the user-friendly panel eases program settings. See Figure 6.

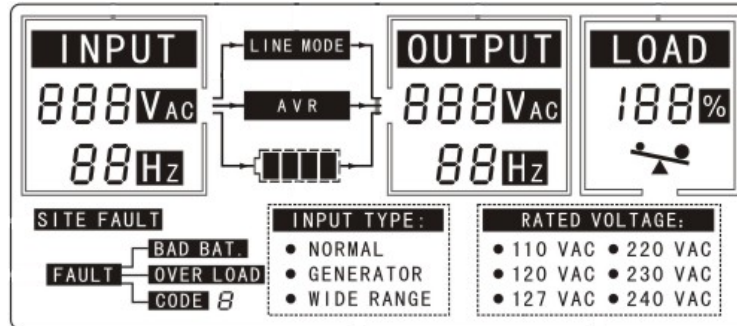



Figure 6 - LCD display interface

- AC Mode Indicator**
 The line mode symbol will show and the indicator will display the input voltage, output voltage and load.
- Inverter Mode Indicator**
 The inverter mode symbol will show and the indicator will display the input voltage, output voltage, load.
 The battery capacity segment will indicate the battery capacity depending on the battery voltage level.
- Charging Indicator**
 When line mode and input within range, the charging symbol will show up. And battery capacity segment will roll flashing in turn basing on capacity.

- Charger mode battery indicator**

Status	Battery Capacity					
		5	4	3	2	1
CC/CV	75% ~ 100%	ON	Flash 1	Solid ON	Solid ON	Solid ON
	50% - 75%	ON	Flash 2	Flash 1	Solid ON	Solid ON
	25% ~ 50%	ON	Flash 3	Flash 4	Flash 1	Solid ON
	0% ~ 25%	ON	Flash 4	Flash 3	Flash 2	Flash 1
	Low Battery	Flash	Flash 4	Flash 3	Flash 2	Flash 1
Floating	Full	ON	Solid ON	Solid ON	Solid ON	Solid ON

- Inverter mode battery indicator**

Battery Capacity						ALARM
	5	4	3	2	1	
Full	ON	ON	ON	ON	ON	--
75%	ON	OFF	ON	ON	ON	--
50%	ON	OFF	OFF	ON	ON	--
25%	ON	OFF	OFF	OFF	ON	--
0%	ON	OFF	OFF	OFF	OFF	--
Low Alarm	Flash	OFF	OFF	OFF	OFF	1 beep / 2s
Off	Flash	OFF	OFF	OFF	OFF	--

- **Load indicator**
The load indicator shows the load percentage in VA or W, whichever is bigger, the overload indicator will flash when an overload is present.

Battery Charger

- **Inverter to Charger Transition**
The internal battery charger and automatic transfer relay allow the inverter/charger to operate as either a battery charger or an inverter (but not both at the same time). The inverter/charger automatically becomes a battery charger whenever AC power is supplied to its AC input. The AC input is internally connected to the AC output while in battery charger mode.
- **Charger Terminology**
 1. **Constant Current Stage** - During this cycle, the batteries are charged at a constant current.
 2. **Constant Voltage Stage** - During this cycle, the batteries are held at a constant voltage (14.1V per 12V block for AGM & GEL, 14.6V per 12V block for FLOODED) and accept whatever current (less than the current in CC stage) is required to maintain this voltage. This ensures full charging.
 3. **Float Stage** - During this cycle, the batteries are held at the float voltage (13.5V per 12V block).
 4. Whenever the AC is reconnected, the charger will reset the above cycle.
 5. If the charger maintains the float state for 21 consecutive days, the charger will reset the cycle.

Circuit Breaker

The inverter/charger contains one input circuit breaker located on the rear panel of the chassis, next to the AC input terminal block. This circuit breaker protects the charger and bypass circuits. The circuit breaker will trigger if the input is over-current. The circuit breaker is push to reset.

SPECIFICATIONS

Table 5 - Line Mode Specifications

MODEL	INVC5048H	INVC5096H
Input Voltage Waveform	Sinusoidal (Utility or Generator)	
Nominal Input Voltage	230Vac	
Low Line Disconnect	170Vac (Normal) 90Vac (Generator / Wide Range)	
Low Line Reconnect	180Vac (Normal) 100Vac (Generator / Wide Range)	
High Line Disconnect	280Vac	
High Line Re-connect	270Vac	
Max AC Input Voltage	300Vac rms	
Nominal Input Frequency	50Hz / 60Hz (Auto-detect)	
Low Line Frequency Disconnect	40±1Hz	
Low Line Frequency Reconnect	42±1Hz	
High Line Frequency Disconnect	65±1Hz	
High Line Frequency Reconnect	63±1Hz	
Output Voltage Waveform	Same as Input Waveform	
Output Short Circuit Protection	Circuit Breaker 40A	
Efficiency (Line Mode)	>95%	
Transfer Switch Rating	40A	
Transfer Time (AC to DC)	10ms (typical) 20ms (typical)	
Transfer Time (DC to AC)	10ms (typical) 20ms (typical)	
Power Limiting	 <p>The graph plots Max Output power on the y-axis against Input Voltage on the x-axis. The x-axis has markers at 90V and 180V. The y-axis has markers at 2.5KVA/2.1KW and 5KVA/4.2KW. The power increases linearly from 90V to 180V, reaching 5KVA/4.2KW at 180V, and then remains constant for higher input voltages.</p>	

Table 6 - Inverter Mode Specifications

MODEL	INVC5048H	INVC5096H
Output Voltage Waveform	Pure Sine Wave	
Rated Output Power	5,000VA	
Power Factor	0.84	
Nominal Output Voltage	230Vac	
Output Frequency	50Hz / 60Hz \pm 1Hz	
Output Voltage Regulation	\pm 10% rms	
Nominal Efficiency	>90%	
Over-Load Protection	fault after 5s@ \geq 150% load fault after 10s@110%~150% load	
Surge rating	10,000VA	
Capable of starting electric motor	2.5HP	
Output Short Circuit Protection	Current limit (Fault after 4 cycles max.)	
Bypass Breaker Size	40A	
Nominal DC Input Voltage	48V	96V
Min DC start voltage	40V	80V
Low DC Alarm	42.0 \pm 1.2Vdc	84.0 \pm 2.4Vdc
Low DC Alarm Recovery	43.2 \pm 1.2Vdc	86.4 \pm 2.4Vdc
Low DC Shut-down	40.0 \pm 1.2Vdc	80.0 \pm 2.4Vdc
Low DC Shut-down Recovery	44.0 \pm 1.2Vdc	88.0 \pm 2.4Vdc
High DC Shut-down	60.0 \pm 1.2Vdc	120.0 \pm 2.4Vdc
High DC Shut-down Recovery ¹	58.0 \pm 1.2Vdc	116.0 \pm 2.4Vdc
Power saver setting	0W (Set "OFF" at LCD) 10W \pm 5W enter 5+/-2W leave (Set "ON" at LCD)	
Tare loss(nominal)	Saver OFF:<50W Saver ON:<10W	
DC component of AC output	<100mV	
Half wave load detection	Yes(when unbalance current>35A)	
Power Limitation		

Note 1: Line voltage must be available for charging.

Table 7 - Charge Mode Specifications

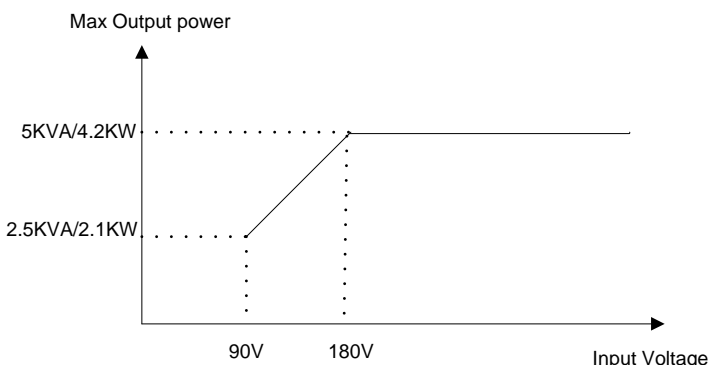
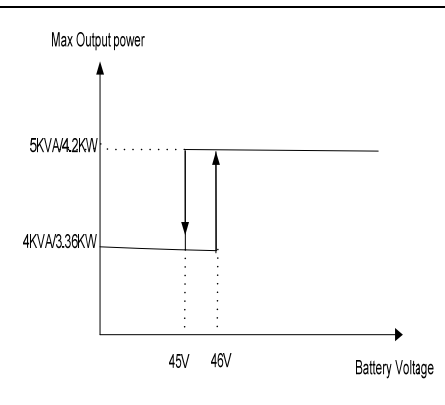
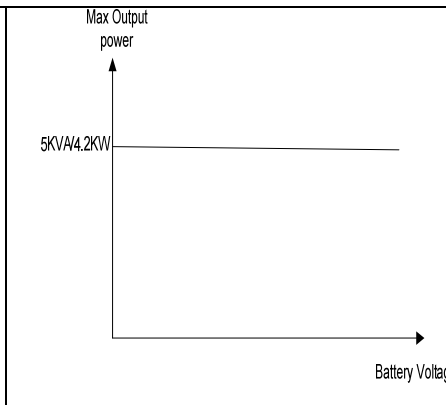
MODEL	INVC5048H	INVC5096H																								
Nominal Input Voltage	230Vac																									
Input Voltage Range	180V~ 270Vac (Normal range) 100V~ 270Vac (Generator / Wide Range)																									
Nominal Output Voltage	Determined by battery type																									
Nominal Charge Current	20A(95-175V, gen/wide only) 35A(175-275V) @ 35A setting 20A(175-275V) @ 20A setting	10A(95-175V, gen/wide only) 20A(175-275V) @ 20A setting 10A(175-275v) @ 10A setting																								
Battery initial voltage(sps setup)	>35Vdc	>70Vdc																								
Charger Short Circuit Protection	Inverter/charger shuts down automatically																									
Over Charge Protection	Batt. V \geq 60Vdc, Fault, Buzzer alarm	Batt. V \geq 120Vdc, Fault, Buzzer alarm																								
Charge Algorithm	Three stage: Boost CC (constant current stage) → Boost CV (constant voltage stage) → Float (constant voltage stage)																									
Battery Type Setting(\pm 0.3V/batt.)	<table border="1"> <thead> <tr> <th rowspan="2">Battery Type</th> <th colspan="2">Boost CC/CV</th> <th colspan="2">Float</th> </tr> <tr> <th colspan="2">Voltage(V)</th> <th colspan="2">Voltage(V)</th> </tr> <tr> <td></td> <td>48</td> <td>96</td> <td>48</td> <td>96</td> </tr> </thead> <tbody> <tr> <td>Flooded</td> <td>58.4</td> <td>116.8</td> <td>53.6</td> <td>108</td> </tr> <tr> <td>AGM/Gel</td> <td>56.4</td> <td>112.8</td> <td>54</td> <td>108</td> </tr> </tbody> </table>		Battery Type	Boost CC/CV		Float		Voltage(V)		Voltage(V)			48	96	48	96	Flooded	58.4	116.8	53.6	108	AGM/Gel	56.4	112.8	54	108
Battery Type	Boost CC/CV			Float																						
	Voltage(V)		Voltage(V)																							
	48	96	48	96																						
Flooded	58.4	116.8	53.6	108																						
AGM/Gel	56.4	112.8	54	108																						
Charger current (+/-10%)	 <p style="text-align: center;">INVC5096H (INVC5048H)</p>																									

Table 8 - General Specifications

Safety Certification	CE(EN60950)
EMI Classification	EN62040-2, CLASS A
Operating Temperature Range	0°C to 45°C
Storage temperature	-15°C ~ 60°C
Altitude, operational	Elevation: 0 ~ 1500 Meters
Relative humidity	5% to 95% non-condensing
Audible Noise	60dB max.
Cooling	Forced air, variable speed fan
Dimension	350mm (w) x 110mm (h) x 407mm (d)
Net Weight	9Kg

Table 9 Fault code/ Audible alarm

Fault Code	Protect Function	Active Mode	Condition	Warning (O/P=ON)	Fault (O/P=OFF)	Restart	
						Operate	Condition
--	Low DC Voltage Alarm	Inverter	DC Voltage <Low DC Alarm	1beep/2s	--	--	--
0	Low DC Voltage Protection	Inverter	DC Voltage <Low DC Shut-down	--	Beep continuous	Auto	Mains is normal
1	Over Charge Protection	Line	DC Voltage >High DC input Shut-down	Beep continuous	--	Manual	--
1	Over Voltage Protection	Standby	DC Voltage >High DC input Shut-down	--	Beep continuous	Auto	DC Voltage<High DC input Shut-down Recovery
2	Over Load Protection	Line/ Inverter	110%~150% load	1beep/0.5s,and continuous 10s	Beep continuous	Manual	--
			>150% load	1beep/0.5s,and continuous 5s	Beep continuous	Manual	--
3	Output Short Circuit Protection	Inverter	Output Voltage<20Vrms	--	Beep continuous	Manual	--
4	Fan Fault Protection	Line/ Inverter	Fan Locked Fan Defected	2beep/2s,and continuous 1min	Beep continuous	Manual	--
5	Over Temp Protection	Line/ Inverter	HEAT SINK Temp≥100°C	--	Beep continuous	Auto	HEAT SINK Temp≤ 55°C
6	Back-EMF Protection	Standby	Reverse input and output	--	Beep continuous	Manual	--
9	Output Abnormal	Inverter	(Output Voltage <170Vrms and output current under 32Arms) or Output Voltage >280Vrms	--	Beep continuous	Manual	--

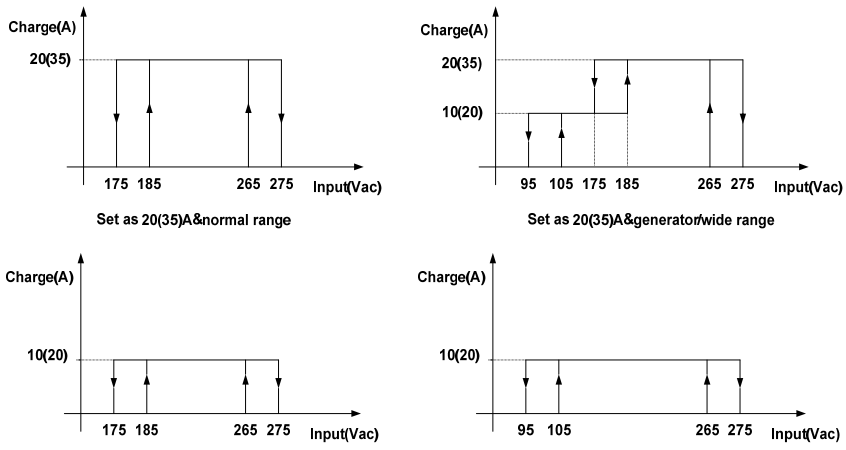
TROUBLESHOOTING

Problem	Possible Causes	Remedy
No LCD display	1. Battery Weak <35V for 5048H <70V for 5096H	1. Re-charge battery
	2. Battery defective (can't be charged)	2. Replace Battery
	3. Power switch is not pressed	3. Press and hold power switch
	4. Battery polarity reversed Can't start up the inverter/charger	4. Return to UNIPOWER for repair
Mains normal but operates in inverter mode	1. AC input missing	1. Check AC input connections
	2. Input breaker triggered	2. Reset the input breaker
Alarm buzzer beeps continuously	1. Overload	1. Verify that the load matches the capability specified
	2. Output short circuit	2. Check wiring or remove abnormal load
	3. Over temp	3. Remove any obstruction in front of airflow inlet
	4. Over charger	4. Restart the inverter/charger
	5. Over voltage	5. lower the DC input voltage under the high DC Input shut-down recovery: 58.0±1.2Vdc for 5048H 116.0±2.4Vdc for 5096H
	6. Fan fault	6. Check for any fan obstruction, if not fan should be replaced
	7. Back-EMF	7. Check the AC Input and output wire connection
	8. DC voltage under the low DC shut-down	8. Make sure mains is normal to recharge the battery if not switch the power off until mains is normal
Back up time is shortened	1. Overload	1. Remove some non-critical load
	2. Battery voltage is too low	2. Charge battery for 8 hours or more
	3. Battery bank is too small	3. Increase battery bank capacity