

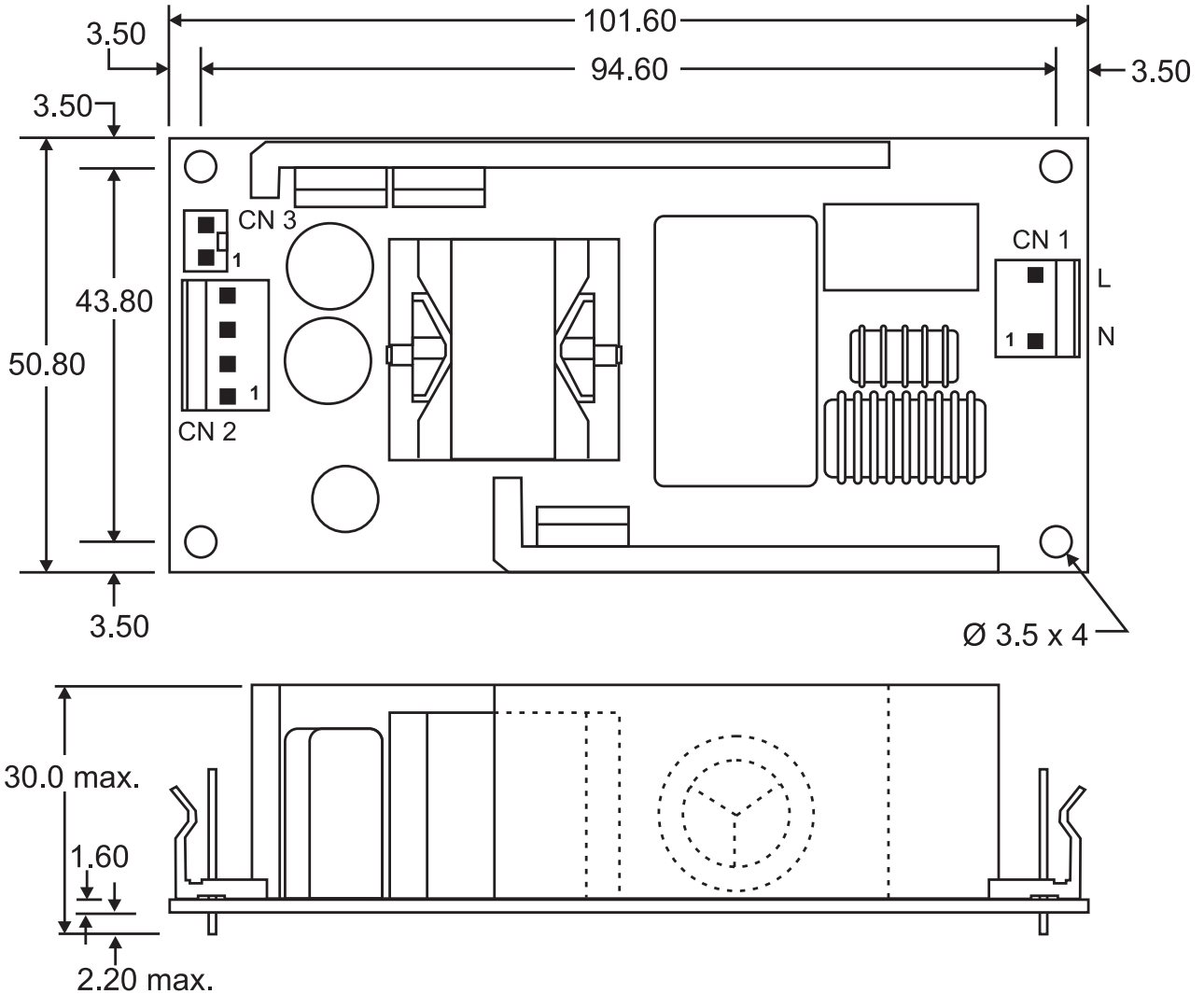

## MECHANICAL SPECIFICATIONS & CONNECTION DETAILS



CONNECTOR PINOUTS	
CN1	See outline drawing
CN2	Pin 1: Output -Ve Pin 2: Output -Ve Pin 3: Output +Ve Pin 4: Output +Ve
CN3	Pin 1: Sense -Ve Pin 2: Sense +Ve

Note: Use of the sense connections is optional.

MATING CONNECTORS	
CN1	Housing: Molex 09-76-1020 or equivalent Pins (2): Molex 08-70-0012 or equivalent
CN2	Housing: Molex 09-52-4044 or equivalent Pins (4): Molex 08-70-0012 or equivalent
CN3	Housing: JST XHP-2 or equivalent Pins (2): JST SXH-001T-P0.6(N) or equivalent

A kit containing one each housing and indicated number of pins is supplied with each unit as standard.